

Godfather's Pizza
Presents

2009 Rice County Fair

Faribault, MN

**DEMOLITION
DERBY**

RULES AND REGULATIONS

Saturday, July 18 - 7:00 pm

Sunday, July 19 - 6:00 pm

Also Sponsored By:

Churchill Tire

Auto Value

Flom Disposal

Faribault Daily News

I.B.E.W.

Harleys Auto Salvage



PO BOX 393
FARIBAULT, MN 55021

Demolition Derby Entry Form - SATURDAY, JULY 18, 2009-6:00 PM

Entry fee of \$40.00 per car must accompany entry form. After July 1st \$50.00 Entry Fee. **Entry fee will admit one driver and one pit man.** Mail entries to following address: Rice County Fair-Demolition Derby, Jim Hermel, Box 393, Faribault, MN 55021. Make checks payable to Rice County Fair - Pit Gate Open 1pm - NO ENTRY FEE REFUNDS.

In consideration of your accepting this entry, I hereby for myself, my heirs, executors, and administrators, release and forever discharge the co-sponsors, their agents, servants, and persons connected with these competitions of and from any and all right, claims, demands, and damage, and actions whatsoever that I may have for any loss, damage or injury sustained by me during said competitions. I also acknowledge that I have read the following resolution and agree that I, my pit man and any other people in my derby crew or family will abide by it. "There will be no drinking of alcoholic beverages in the pit area of the grandstand before, during or after the grandstand shows. Violators will be subject to arrest and disqualification from the scheduled events."

	<i>PLEASE CHECK ONE</i>
	FULL-SIZE PASSENGER
	COMPACT
	PICKUP TRUCKS
	C-W NEWER
	MINI VAN
	POWER PUFF - Saturday (C-W RULES) ONLY

(Signed) _____
Driver

NAME _____

ADDRESS _____

CITY/STATE/ZIP _____

TELEPHONE NO. (Area Code) _____ AGE _____

NO. OF CAR/TRUCK _____ ALTERNATE NO. _____

YEAR _____ MAKE _____ MODEL _____

SPONSOR _____

Demolition Derby Entry Form - SUNDAY, JULY 19, 2009 - 6:00 PM

Entry fee of \$40.00 per car must accompany entry form. After July 1st \$50.00 Entry Fee. **Entry fee will admit one driver and one pit man.** Mail entries to following address: Rice County Fair-Demolition Derby, Jim Hermel, Box 393, Faribault, MN 55021. Make checks payable to Rice County Fair - Pit Gate Open 1pm - NO ENTRY FEE REFUNDS.

In consideration of your accepting this entry, I hereby for myself, my heirs, executors, and administrators, release and forever discharge the co-sponsors, their agents, servants, and persons connected with these competitions of and from any and all right, claims, demands, and damage, and actions whatsoever that I may have for any loss, damage or injury sustained by me during said competitions. I also acknowledge that I have read the following resolution and agree that I, my pit man and any other people in my derby crew or family will abide by it. "There will be no drinking of alcoholic beverages in the pit area of the grandstand before, during or after the grandstand shows. Violators will be subject to arrest and disqualification from the scheduled events."

	<i>PLEASE CHECK ONE</i>
	FULL-SIZE PASSENGER
	COMPACT
	PICKUP TRUCKS
	C-W NEWER
	MINI VAN
	MIDSIZE - Sunday ONLY

(Signed) _____
Driver

NAME _____

ADDRESS _____

CITY/STATE/ZIP _____

TELEPHONE NO. (Area Code) _____ AGE _____

NO. OF CAR/TRUCK _____ ALTERNATE NO. _____

YEAR _____ MAKE _____ MODEL _____

SPONSOR _____

RULES AND REGULATIONS

GENERAL RULES

A. Only drivers who have filled out entry applications and have been approved by Rice County Fair management may compete. Management reserves the right to accept or reject any entry. There will be no refund of entry fees for any reason.

B. Changing drivers is not allowed. **Drivers must be at least 16 years of age and in possession of a valid driver's license and a signed and notarized parental consent form for any driver 16-17 years of age.**

C. Drivers are responsible for the conduct of team members. At the sole discretion of fair management, driver or team members conduct not in the best interest of Rice County Fair during competition or any other time will result in disqualification and expulsion.

D. Possession or drinking of alcoholic beverages in the pits area before, during or after demolition derbies is prohibited. Violation of this rule will result in team disqualification and immediate expulsion.

E. Entry fee is \$40.00 per car. This must accompany entry form with check made payable to the Rice County Fair. After July 1, 2009 - Entry fee will be \$50.00.

F. Winnings will be paid by check each night of the demolition derbies. Drivers must provide social security number and if winnings are more than \$600 a federal tax form 1099 will be filed in January.

G. Frame stuffing or frame reinforcement is not allowed. No expandable foam in any body cavity. If frame stuffing / reinforcement is found you are automatically disqualified for the entire event. **NO EXCEPTIONS!!!!**

H. *Frame tears can only be repaired with 1" wide x 1/4" thick straps and straps must run parallel to the tear. Frame bends can be repaired with 4x4 1/4" plate.*

I. *Frames will be randomly bore-scoped inspected.*

J. *No mud covered frames or underbodies at the pre-race inspection - automatic disqualification - NO EXCEPTIONS!!!*

K. *All airbags must be removed.*

L. FAILURE TO COMPLY WITH ALL WRITTEN REGULATIONS WILL RESULT IN DISQUALIFICATION OF DRIVER FOR THE CURRENT YEAR AND THE FOLLOWING YEAR.

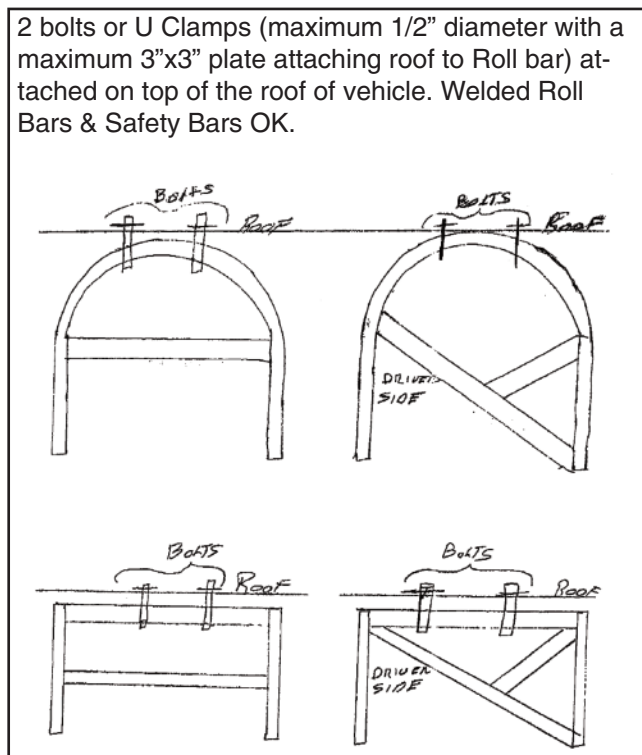

COMPETITION RULES:

- A. Any car, truck or driver that is unsafe will be disqualified. In all matters judges' decisions are final.
- B. A colored flag will be placed on each car. Driver must break off flag when no longer running or after having been disqualified. Do not hit cars with broken flags.
- C. Drivers must wear approved safety helmets and seat belts.
- D. Driver must hit another car within the time limit announced by judges or be disqualified. "Playing possum" will lead to disqualification.
- E. Trucks or cars may be driven forward or backwards. Head-on collisions and *intentional* hitting on driver's side door are prohibited and will lead to disqualification *if observed by a track official*.
- F. Trucks or cars that have all four wheels out either end of the track either by being driven or pushed will be disqualified.
- G. Drivers must stay in cars with seat belts fastened until checkered flag is waved for the winner.
- H. Towing will be handled by towing company designated by fair management. No other tow trucks are allowed in the arena.
- I. All cars must be removed from the fairgrounds within 12 hours of end of competition.
- J. *When there are 4 vehicles left moving in the field, you **cannot** hit the same vehicle more than two consecutive times until the field is down to 2 moving vehicles.*

CHECK IN

- A. \$40.00 derby entry fee will include two pit passes. These will be mailed to you. Additional pit passes are \$20.00 each and will only be sold the day of the event at the pit gate.
- B. Everyone entering the pits must have a pit pass and sign a waiver. ***Absolutely no one under 16 years of age will be admitted to the pits. NO EXCEPTIONS! MUST HAVE A VALID PICTURE ID***
- C. Only competition car, hauler and one other vehicle for each team will be admitted to the pits.
- D. **All vehicles must be on the grounds at 6:00 pm on Saturday and 5:00 pm on Sunday for inspection. There will be a mandatory driver's meeting at 6:45 pm Saturday & 5:45 pm Sunday. Drivers and cars must check in before the driver's meeting. No driver will be allowed to compete if they check in after driver's meeting. DON'T BE LATE!!!**
- E. Hoods and trunks of competition cars must be open at pit gate for inspection.

REGULAR PASSENGER CARS

PROGRAM:

- A. One 16 car heat - if we have more than 16 cars, we will have two events in this class.
- B. Winner will receive \$1,000, second \$500, third \$400, fourth \$150, fifth \$100, sixth \$50, seventh \$50; trophies for first through third.

SPECIFICATIONS:

- A. Any hardtop cars, including station wagons, are allowed except Imperials, ambulances, hearses and carryalls. Cross-breeding of motors is allowed.
- B. Exterior molding, license plates and glass, including head and tail lights must be removed before entering the fairgrounds. The rear seat must be removed. All dirt, debris and other loose pieces must be swept out.
- C. Gas tank must be strapped in back seat and covered; tank can be metal or plastic and cannot hold more than five gallons of fuel. The original tank must be removed or dropped. No electric fuel pumps unless standard equipment.
- D. Cooling system must be original equipment and must contain water only. Trans Coolers are allowed.
- E. Any car bumper is allowed. Bumper may be welded to frame but with no extra reinforcement. *Bumpers cannot be installed upside down.* No trailer hitches or other reinforcement.
- F. All body parts, including fenders, must be in place. **Trunks, body and frame may not be welded for reinforcement.** Pre-bending of sheet metal is allowed.
- G. External door skins can be welded. 5 on 5 off, no welding on inside of doors.
- H. Cars must have standard suspension. No welding of front or rear suspension.
- I. No extra battery allowed in car. There is no battery size limitation.
- J. Car hood and trunk must be held down using two single strands of chain (3/8" max), or #9 wire, maximum of 4 strands. 2 thru cowl and hood also allowed for safety. Or maximum 4 bolts, 1" threaded rod, max 5" washer. 2 bolts allowed in trunk. NOTHING thru fenders. Two 6" diameter holes must be cut in hood (fire access).
- K. Minimum 2" and maximum 3" tubing MUST be placed in car running from post to post behind driver's seat with maximum 12" square end plates permanently attached to car's body. If dashboard is removed, a safety bar with minimum 2" and maximum 3" tubing and 6" square mounting plates must be installed in its place. A roll bar manufactured from minimum 2" and maximum of 3" tubing can be installed for driver protection. Roll bar must abut to the back of the driver's seat or safety bar, no kickers. Passenger side safety bar is allowed. Roll bar may go over roof.
- L. Each driver must have a fully functional five-pound ABC fire extinguisher on site in tow vehicle.
- M. Car number must be on both front doors, rear lid and roof; no advertising or other signage in these areas. No upright signs higher than 12" or longer than 24" on car roof.
- N. Driver's door may be reinforced with maximum of 1" thick plating extending no more than 3" past door opening seams, and no more than 24" wide.
- O. *Body bolts cannot be larger than 3/4" in diameter with 3"x3"x1/4" plate in original positions.*
- P. Only 2 extra leaf spring clamps per side.
- Q. Valve stem protection is allowed. No Limit on tires.

PICK UP TRUCKS

PROGRAM:

- A. One 16 truck event - if we have more than 16 trucks, we will have two events in this class.
- B. Winner will receive \$750, second \$500, third \$400 fourth \$150, fifth \$110, sixth \$100, seventh \$50.00; trophies for first through third.

SPECIFICATIONS:

- A. **Any one-half or three-fourth ton pickup trucks are eligible.**
- B. Engines must fit body manufacturer (i.e. Ford engine in Ford, Chevrolet engine in Chevrolet, etc.)
- C. Exterior molding, license plates and glass, including head and tail lights must be removed before entering the fairgrounds. All dirt, debris and other loose pieces must be swept out.
- D. Box must be bolted to cab with four bolts 3/4" max, with 6"x6" plate OR welded to cab only.
- E. Box must be attached to frame with four chains (3/8" max), u-bolts or 3/4" bolts with max 6"x6" plate on top; tailgate must be welded or chained.
- F. Four-wheel drive trucks must have front drive shaft removed.
- G. Split rims must be welded in at least 4 locations, 2" weld. No lift kits.
- H. Gas tank must be securely fastened 12" behind the cab. An 8"x8" hole must be cut between the box and cab for the gas line. Tank can be metal or plastic and cannot hold more than five gallons of fuel. The original tank must be removed or dropped. No electric fuel pumps unless standard equipment.
- I. Cooling system must be original equipment and must contain water only. Trans Coolers allowed.
- J. Original bumper may be welded to frame but with no extra reinforcement. Passenger car bumpers may be used as long as they are of the same manufacturer (i.e. Ford to Ford, Chevrolet to Chevrolet, etc.) The front of the bumper cannot be installed more than 10" away from the front of the frame and mounting brackets cannot extend more than 6" into the frame. *Bumpers cannot be installed upside down.* No trailer hitches or other reinforcement.
- K. All doors should be welded shut.
- L. Trucks must have standard suspension. No welding of the front or rear suspension.
- M. Battery must be securely fastened in the front seat area. No extra battery allowed in truck.
- N. Hood must be held down using two single strands of chain. (3/8" max) or #9 wire, maximum of 4 strands and 2 thru cowl and hood. Or maximum 4 bolts, 1" threaded rod, max 5" washer. NOTHING thru fenders. Two 6" holes must be cut in hood (fire access).
- O. Minimum 2" and maximum 3" tubing MUST be placed in truck running from post to post behind driver's seat with maximum 12" square end plates permanently attached to truck's body. If dashboard is removed, a safety bar with minimum 2" and maximum 3" tubing and 6" square mounting plates must be installed in its place. A roll bar manufactured from minimum 2" and maximum of 3" tubing can be installed for driver protection. *Roll bar must be inside the cab, but may go thru and over the roof.*
- P. Each driver must have a fully functional five-pound ABC fire extinguisher on site in tow vehicle.
- Q. Truck number must be on both front doors and roof; no advertising or other signage in these areas. No upright signs higher than 12" or longer than 24" on truck roof.
- R. Driver's door may be reinforced with maximum of 1" thick plating extending no more than 3" past door opening seams, and no more than 24" wide.
- S. *Body bolts cannot be larger than 3/4" in diameter with 3"x3"x1/4" plate in original positions.*
- T. *Valve stem protection allowed. No limit on tires.*

MINI VAN CLASS

PROGRAM:

- A. One 14 car heat - if we have more than 14 cars, we will have two heats in this class.
- B. Winner will receive \$510, second \$400, third \$350, fourth \$100, fifth \$75, sixth \$50, seventh \$40; trophies for first through third.

SPECIFICATIONS:

- A. **Any Mini Van allowed.**
- B. Exterior molding, license plates and glass, including head and tail lights must be removed before entering the fairgrounds. The rear seat must be removed. All dirt, debris and other loose pieces must be swept out.
- C. Gas tank must be strapped in back seat and covered; tank can be metal or plastic and cannot hold more than five gallons of fuel. The original tank must be removed or dropped. No electric fuel pumps unless standard equipment.
- D. Cooling system must be original equipment and must contain water only. Trans Coolers are allowed.
- E. Any mini van bumper allowed. Bumper may be welded to frame but with no extra reinforcement. *Bumpers cannot be installed upside down.* No trailer hitches or other reinforcement.
- F. All body parts, including fenders, must be in place. **Trunks, body and frame may not be welded for reinforcement.** Pre-bending of sheet metal is allowed.
- G. External door skins can be welded. 5 on 5 off, no welding on inside doors.
- H. Van must have standard suspension. No welding of front or rear suspension.
- I. No extra battery allowed in van. There is no battery size limitation.
- J. Van hood must be held down using two single strands of chain (3/8" max), or #9 wire, maximum of 4 strands. 2 thru cowl and hood also allowed for safety. Or maximum 4 bolts, 1" threaded rod, max 5" washer. 2 bolts allowed in trunk. **NOTHING** thru fenders. Two 6" diameter holes must be cut in hood (fire access).
- K. Minimum 2" and maximum 3" tubing **MUST** be placed in car running from post to post behind driver's seat with maximum 12" square end plates permanently attached to car's body. If dashboard is removed, a safety bar with minimum 2" and maximum 3" tubing and 6" square mounting plates must be installed in its place. A roll bar manufactured from minimum 2" and maximum of 3" tubing can be installed for driver protection. Roll bar must abut to the back of the driver's seat or safety bar, no kickers. Passenger side safety bar is allowed. Roll bar may go over roof.
- L. Each driver must have a fully functional five-pound ABC fire extinguisher on site in tow vehicle.
- M. Van number must be on both front doors, rear lid and roof; no advertising or other signage in these areas. No upright signs higher than 12" or longer than 24" on car roof.
- N. Driver's door may be reinforced with maximum of 1" thick plating extending no more than 3" past door opening seams, and no more than 24" wide.
- O. *Body bolts cannot be larger than 3/4" in diameter with 3"x3"x1/4" plate in original positions*
- P. No Implement or skid loader tires are allowed.
- Q. Valve stem protection is allowed.

SPECIAL MIDSIZE CLASS

PROGRAM:

- A. One 16 car heat - if we have more than 16 cars, we will have two events in this class.
- B. Winner will receive \$550, second \$450, third \$175, fourth \$100, fifth \$75, sixth \$50, seventh \$40; trophies for first through third.

SPECIFICATIONS

- A. **Wheelbase specifications are 102" to 112" center of front axle to center of rear axle.**
- B. Any hardtop cars, including station wagons, are allowed *except* ambulances, hearses and carryalls. Engines must fit body manufacturer (i.e. Ford engine in Ford, Chevrolet engine in Chevrolet, etc.)
- C. Exterior molding, license plates and glass, including head and tail lights must be removed before entering the fairgrounds. The rear seat must be removed. All dirt, debris and other loose pieces must be swept out.
- D. Gas tank must be strapped in back seat and covered; tank can be metal or plastic and cannot hold more than five gallons of fuel. The original tank must be removed or dropped. No electric fuel pumps unless standard equipment.
- E. Cooling system must be original equipment and must contain water only. Trans Coolers are allowed.
- F. Any Midsize car bumper allowed. Bumper may be welded to frame but with no extra reinforcement. *Bumpers cannot be installed upside down.* No trailer hitches or other reinforcement.
- G. All body parts, including fenders, must be in place. **Trunks, body and frame may not be welded for reinforcement.** Pre-bending of sheet metal is allowed.
- H. External door skins may be welded, 5 on 5 off. No welding on inside of doors.
- I. Cars must have standard suspension. No welding of front or rear suspension.
- J. No extra battery allowed in car. There is no battery size limitation.
- K. Car hood and trunk must be held down using two single strands of chain (3/8" max), or #9 wire, maximum of 4 strands. 2 thru cowl and hood also allowed for safety. Or maximum 4 bolts, 1" threaded rod, max 5" washer. 2 bolts allowed in trunk. **NOTHING** thru fenders. Two 6" diameter holes must be cut in hood (fire access).
- L. Minimum 2" and maximum 3" tubing **MUST** be placed in car running from post to post behind driver's seat with maximum 12" square end plates permanently attached to car's body. If dashboard is removed, a safety bar with minimum 2" and maximum 3" tubing and 6" square mounting plates must be installed in its place. A roll bar manufactured from minimum 2" and maximum of 3" tubing can be installed for driver protection. Roll bar must abut to the back of the driver's seat or safety bar, no kickers. Passenger side safety bar is allowed. Roll bar may go over roof.
- M. Each driver must have a fully functional five-pound ABC fire extinguisher on site in tow vehicle.
- N. Car number must be on both front doors, rear lid and roof; no advertising or other signage in these areas. No upright signs higher than 12" *or longer than 24"* on car roof.
- O. Driver's door may be reinforced with maximum of 1" thick plating extending no more than 3" past door opening seams, and no more than 24" wide.
- P. *Body bolts and mounts MUST BE STOCK.*
- Q. *No Implement or skid loader tires are allowed.*

C-W 80 NEWER CLASS

PROGRAM:

- A. One 16 car heat - if we have more than 16 cars, we will have two heats in this class.
- B. Winner will receive \$520, second \$400, third \$250, fourth \$80, fifth \$75, sixth \$50, seventh \$40; trophies for first through third.

SPECIFICATIONS:

- A. **Allowed in this class: '79 & newer Mopar, '77 & newer GM, and '77 & newer Ford vehicles.**
- B. **Minimum hub center to hub center wheelbase measurement has to be at least 113".**
- C. Everything must remain stock. NO WELDING, except driver's door and safety bars.
- D. Any hardtop cars, including station wagons, are allowed except Imperials, ambulances, hearses and carryalls. Cross breeding of motors is allowed.
- E. Exterior molding, license plates and glass, including head and tail lights must be removed before entering the fairgrounds. The rear seat must be removed. All dirt, debris and other loose pieces must be swept out.
- F. Gas tank must be strapped in back seat and covered; tank may be metal or plastic and cannot hold more than five gallons of fuel. The original tank must be removed or dropped. No electric fuel pumps unless standard equipment.
- G. Cooling system must be original equipment and must contain water only. No extra Trans Coolers.
- H. Any 80's or newer car bumper allowed. No trailer hitches or other reinforcement.
- I. All body parts, including fenders, must be in place and not cut in any way. Trunks and body frame may not be welded for reinforcement. Pre-bending of sheet metal is allowed.
- J. External door skins can be welded, 5 on 5 off, no welding on inside of door.
- K. Cars must have standard suspension. No welding of front or rear suspension.
- L. No extra battery allowed in car. There is no battery size limitation.
- M. Car hood and trunk must be held down using two single strands of chain (3/8" max), or #9 wire, maximum of 4 strands. 2 thru cowl and hood allowed for safety. Or maximum 4 bolts, 1" threaded rod, max 5" washer. 2 bolts allowed in trunk. NOTHING thru fenders. Two 6" diameter holes must be cut in hood (fire access).
- N. Minimum 2" and maximum 3" tubing MUST be placed in car running from post to post behind driver's seat with maximum 12" square end plates permanently attached to truck's body. If dashboard is removed, a safety bar with minimum 2" and maximum 3" tubing and 6" square mounting plates must be installed in its place. A roll bar manufactured from minimum 2" and maximum of 3" tubing can be installed for driver protection. Roll bar must abut to the back of the driver's seat or safety bar, no kickers. Passenger side safety bar is allowed. *Roll bar may go over roof.*
- O. Each driver must have a fully functional five-pound ABC fire extinguisher on site in tow vehicle.
- P. Car number must be on both front doors, rear lid and roof; no advertising or other signage in these areas.
- Q. No upright signs higher than 12" or longer than 24" on car roof.
- R. Driver's door may be reinforced with maximum of 1" thick plating extending no more than 3" past door opening seams, and no more than 24" wide.
- S. *Body bolts & mounts must remain stock.*
- T. Only 2 extra leaf spring clamps per each side.
- U. Passenger car tires and rims must be stock, valve stem protection is allowed. No skid steer or implement tires allowed.
- V. Shifters may be moved to the floor.

POWDER PUFF - Saturday ONLY

PROGRAM:

- A. Must have minimum 8 cars to run this class
- B. Winner will receive \$450, second \$400, third \$350, fourth \$250, fifth \$75, sixth \$50; trophies for first through third.

SPECIFICATIONS:

- A. **SAME AS C-W 80 NEWER CLASS.**

<u>COMPACT CLASS</u>		<u>C-W NEWER</u>	
3 Trophys in Class		3 Trophys in Class	
1 - \$575.00	5 - \$100.00	1 - \$520.00	5 - \$75.00
2 - \$450.00	6 - \$60.00	2 - \$400.00	6 - \$50.00
3 - \$400.00	7 - \$50.00	3 - \$250.00	7 - \$40.00
4 - \$100.00		4 - \$80.00	
<u>TRUCKS CLASS</u>		<u>MIDSIZE CLASS</u>	
3 Trophys in Class		3 Trophys in Class	
1 - \$765.00	5 - \$110.00	1 - \$550.00	5 - \$75.00
2 - \$500.00	6 - \$100.00	2 - \$450.00	6 - \$50.00
3 - \$400.00	7 - \$50.00	3 - \$175.00	7 - \$40.00
4 - \$150.00		4 - \$100.00	
<u>MINI VAN CLASS</u>		<u>REG. PASSENGER</u>	
3 Trophys in Class		3 Trophys in Class	
1 - \$510.00	5 - \$75.00	1 - \$1,015.00	5 - \$200.00
2 - \$400.00	6 - \$50.00	2 - \$500.00	6 - \$100.00
3 - \$350.00	7 - \$40.00	3 - \$400.00	7 - \$40.00
4 - \$100.00		4 - \$250.00	
<u>POWDER PUFF CLASS</u>			
3 Trophys in Class			
1 - \$450.00	4 - \$250.00		
2 - \$400.00	5 - \$75.00		
3 - \$350.00	6 - \$50.00		

	<p>SAVE \$3.00 On Any JUMBO SPECIALTY PIZZA</p> <p><small>With this coupon, at Faribault, Owatonna or Waseca through 8-01-09. Not valid with any other coupon or special offers.</small></p>
---	---